

INSTALLATION INSTRUCTION

for the correct installation of isoloc Levelling Discs NT, NTE, NTR, NTS and NTSE

General installation guidelines:

Before installing the machine or plant, the area around the bearing surface must be free from oil and grease in order to give optimum anti-slip protection. This can be achieved by using solvents, e. g. acetone. Rough concrete should be given clean smooth coating. The admissible evenness and angle tolerances on the upper side of the bearing surfaces and on the lower side of the machine pedestals base on DIN 18202. Localized loads have to be avoided. For special problems please contact isoloc Schwingungstechnik GmbH, Stuttgart, Germany. If the centre of gravity is not central different sizes of the elements (disc Ø) have to be used, if necessary. It should additionally be ensured that the maximum force due to weight (F_{max} in N) specified in our isoloc brochure is not exceeded. The indicated max. load/element refers always to the sum of the statically and dynamically acting forces. **After placing the machine it may no longer be shifted!** For machines with shear forces higher than 0.5 kN we recommend our UMS Machine Shoes. Set down the machine as low as possible on the levelling bolts or levelling nuts. Where required, please ask us for examination.

1.0 Levelling Discs NT, NTR and NTE

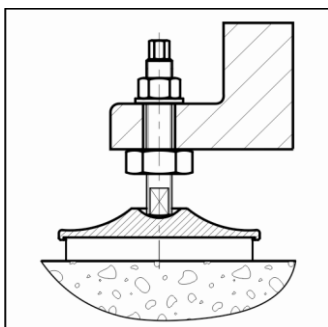

Raise the machine with suitable lifting devices so far that the NT- or NTE-elements can be put underneath it. Insert the levelling bolt, without the lower (partly bigger) levelling nut, into the hole through the machine foot from above. Following this, screw on the levelling nut from below onto the levelling bolt. Insert the isoloc levelling bolt by means of the levelling nut in that way that it is in the spherical recess of the levelling disc. The adjusting screw has to be vertically in the through bore-hole. Perform these preparations at all the support points, lower the machine carefully and level it by means of the levelling nut with the specified spanner size, holding the upper levelling bolt hexagon or the lower two flats of the levelling bolt. Once the levelling has been completed, screw the upper lock nut with its washer on the levelling bolt and tighten it.

NB:

The levelling bolts for NT- and NTE-elements additionally incorporate a spanner surface at the bottom. This means that in the case of machines with threads in the machine foot, it is possible to perform levelling from below without the lower levelling nut. Only isoloc levelling bolts may be used.

1.1 Levelling Discs NTS 50, 80, 100, 120, 150, 200, 250 and 300

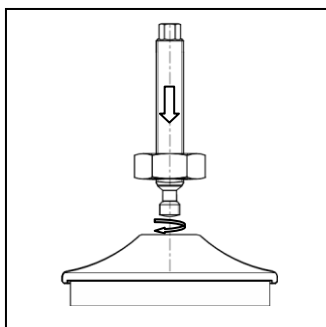

fig. 1.1.2

As first step, turn the lower, partly bigger levelling nut onto the levelling bolt at the same height on all levelling discs. Screw the bolt with the thread at its end so long into the levelling disc (fig. 1.1.2) until the bolt can be freely moved and swiveled. Levelling disc and bolt are then undetachably connected. Lift the machine so far that the NTS- or NTSE-elements with the bolt (fig. 1.1.3) can be put underneath it. Please do not enter under the suspended machine – risk of accident! The entire element is then inserted from below into the prepared bore holes of the machine foot so that the bottom side of the machine foot rests directly on the levelling nut. The lock nut and washer should then be screwed from above onto the levelling bolt so that the levelling disc cannot drop down. All levelling discs mounted, lower the machine carefully and slowly onto them.

Then level the machine using a suitable tool (ring / combination spanner) with the specified spanner size, holding the upper hexagon of the levelling bolt. Once the levelling has been completed, tighten the upper lock nut (with washer) (fig. 1.1.4).

The NTS-elements can be used to smooth out unevenness of 3° - 5° in the floor.

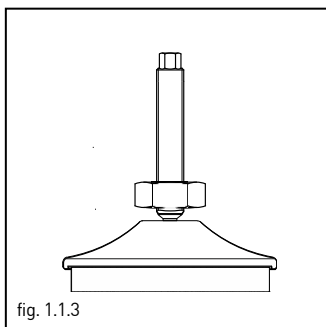

fig. 1.1.3

NB:

The levelling bolt for NTS- and NTSE-elements additionally incorporate a spanner surface at the bottom. This means that in the case of machines with threads in the machine foot, it is possible to perform levelling without the lower levelling nut.

If you transport or replace a machine with mounted NTS- or NTSE-Levelling Discs, please ensure when raising and lowering the machine that it does not swing (fig. 2).

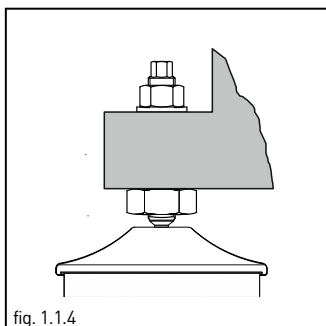

fig. 1.1.4

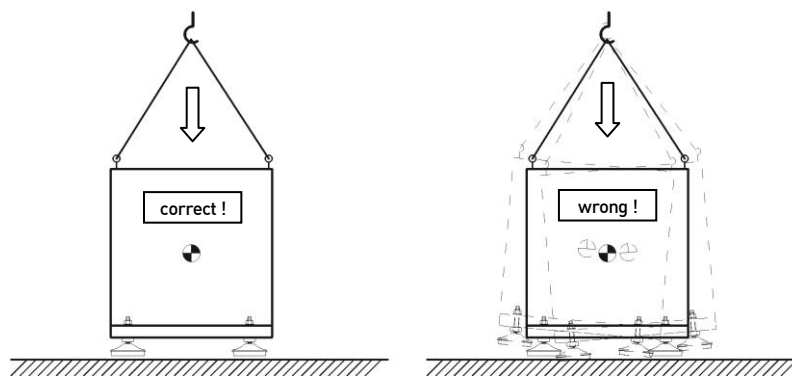

fig. 2